

SETINA K-9

ULTIMATE K-9 INSERT

The Total K-9 System

The Ultimate K-9 Insert features the Largest-in-Class K-9 Containment Area with Setina's Best-Selling Rear Cargo Storage Management System. Constructed of Heavy-Duty, Light-Weight, Corrosion Resistant Aluminum Alloy with a Rugged Powder Coat Finish. Designed for Easy Installation and Easy Spare Tire Access.



The Ultimate in K-9 transport

Ultimate K-9 Insert provides handlers Front and Side K-9 Deployment Points, It comes with a Removable 1/2" thick, padded non-skid rubber floor mat. Aluminum and TPO Door Guards One black powder coated Aluminum K-9, door guard.



THE TOTAL K-9 SYSTEM

TOTAL K-9, PRISONER, & CARGO TRANSPORT

Provides Front and Side K-9 Deployment Points, as well as Prisoner Transport And Rear Cargo Storage



ADDITIONAL OPTIONS:

Easy-Lift Cargo Deck Storage.

(Not Included,)

Premier K-9 Electronics Available.

(Not Included,)

SETINA

Visit us at: www.setina.com

SETINA K-9

K-9 Transport Systems

EQUIPMENT FOR THE K-9 TEAM

A K-9 INSERT SYSTEM

- Aircraft Grade Aluminum Construction
- Front Partition with Sliding Door for K-9 Front and Side Exits.
- Removable 1-1/2" Non-Skid Rubber Floor Mat.
- Aircraft Grade Aluminum Door Guards.
- Hinged Window Barriers for Easy Cleaning.
- Optional: Window Barriers with Cutout & Fan for added ventilation.

(Durango, Ford Utility and Tahoe PPV, Charger)

B K-9 RETROFIT UNIT

- Aircraft Grade Aluminum Construction.
- Removable 1 1/2" Non-Skid Rubber Floor Mat.
- Aircraft Grade Aluminum Door Guards.
- Hinged Window Barriers for Easy Cleaning.
- Optional: Window Barriers with Cutout and Fan for Additional Ventilation.

(SUV'S require Front and Rear Partitions - Sold Separately)

(Cars and Trucks Require a Front Partition - Sold Separately)

Durango, Ford Utility and Tahoe PPV, Charger

C K-9 ULTIMATE II - K-9 & SINGLE PRISONER TRANSPORT SYSTEM

- Aircraft Grade Aluminum Construction.
- Front Partition with Sliding Door for K-9 Front and Side Exits.
- Aluminum Divider Wall with Ventilation Slots and Polycarbonate Rear Cargo Barrier.
- Removable 1-1/2" Non-Skid Rubber Floor Mat.
- Aluminum Door Guard K-9 side and TPO Door Guard on passenger side.
- Hinged Window Barriers for Easy Cleaning.
- Optional: Window Barriers with Cutout and Fan for Additional Ventilation.
- TPO Single Prisoner Seat Included for Ford Utility.
- Aluminum Single Prisoner Seat Available for Tahoe PPV.

(Cargo Box & K-9 Electronics Sold Separately)

Durango, Ford Utility and Tahoe PPV

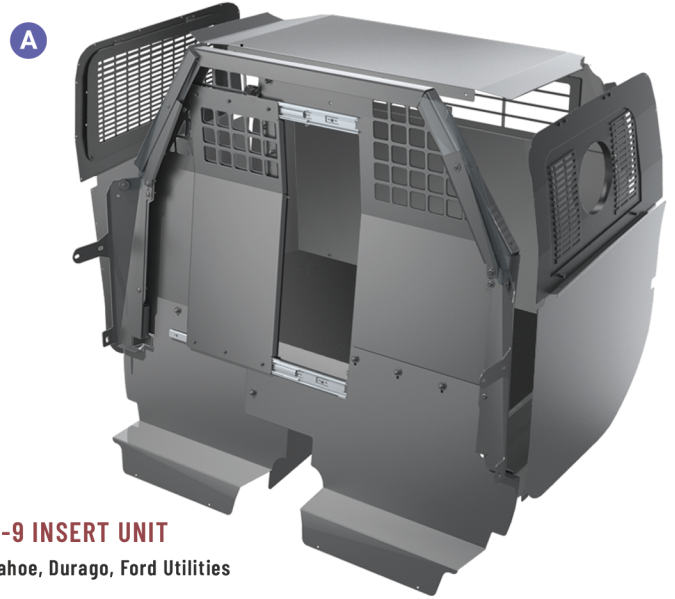

K-9 INSERT UNIT

Tahoe, Durago, Ford Utilities



K-9 RETROFIT UNIT

Tahoe, Durago, Ford Utilities

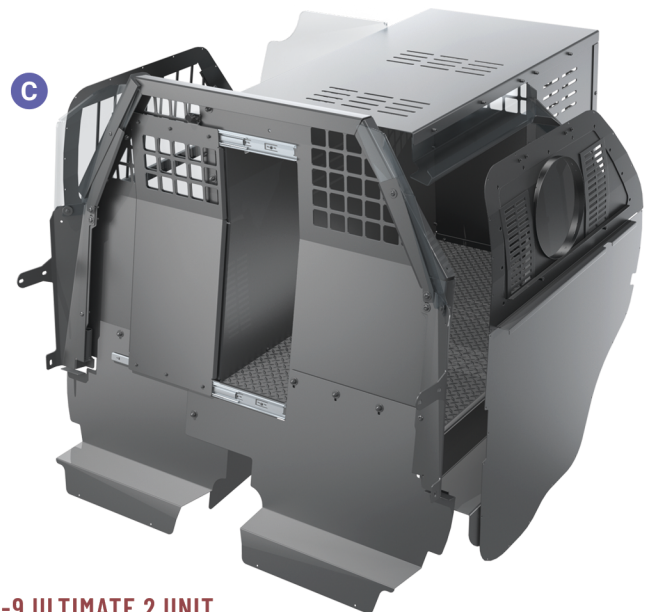

K-9 ULTIMATE 2 UNIT

Tahoe, Durago, Ford Utilities